

WCR A425 DUO

PLATE HEAT EXCHANGER

Suitable for sanitary applications, the A425 Duo model is ideally suited for process security. The unique double wall design allows for individual plate inspection and dye testing not commonly found with laser welded pairs.

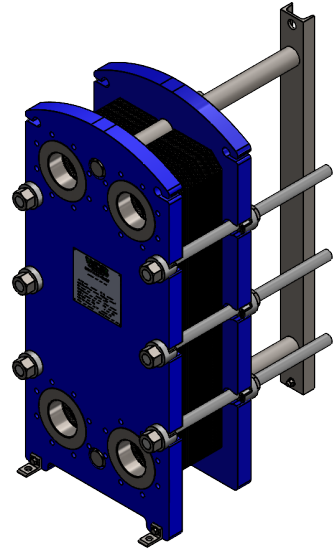

APPLICATIONS

- Biotech and Pharmaceutical
- Chemicals
- Energy and Utilities
- Food and Beverages
- Home and Personal Care
- HVAC and Refrigeration
- Machinery and Manufacturing
- Marine and Transportation
- Mining, Minerals and Pigments
- Pulp and Paper
- Semiconductor and Electronics
- Steel
- Water and Waste Treatment

BENEFITS

- Double Pressed Duo Plate Design Allows for Complete Process Security Ensuring Critical Fluids Leak to Atmosphere in the Event of Plate Fatigue
- Completely Serviceable – Plates Can Be Separated to Allow for Complete Chemical Cleaning and Non-destructive Testing
- High Energy Efficiency – Low Operating Cost
- Flexible Configuration – Heat Transfer Area Can Be Modified
- Easy to Install – Compact Design
- High Serviceability – Easy to Open for Inspection and Cleaning, and Easy to Clean by CIP
- Access to WCR's Global Service Network

FEATURES

Every detail is carefully designed to ensure optimal performance, maximum uptime and easy maintenance. Selection of available features:

- Non-Laser Welded Duo Plate Type
- Stepped Duo Port Gasket
- Glued Gasket
- Clip-on Gasket
- Leak Chamber
- Fixed Bolt Head
- Key Hole Bolt Opening
- Lifting Lug
- Lining
- Lock Washer
- Tightening Bolt Cover

Ready at a moment's notice to keep your business flowing smoothly

WCR's comprehensive field and factory service and support network ensures that your equipment will continue to operate with maximum efficiency and effectiveness throughout its life cycle. WCR operates the largest gasket and plate manufacturing facility in North America and stocks a massive inventory of replacement plates and gaskets.

Start-up Support

- Installation
- Installation Supervision
- Commissioning

Maintenance

- Cleaning Services
- Reconditioning Improvements
- Repair
- Service Tools
- Spare Parts

Support

- Exclusive Stock
- Technical Documentation
- Telephone Support
- Training
- Troubleshooting

Improvements

- Equipment Upgrades and Redesign
- Replacement and Retrofit

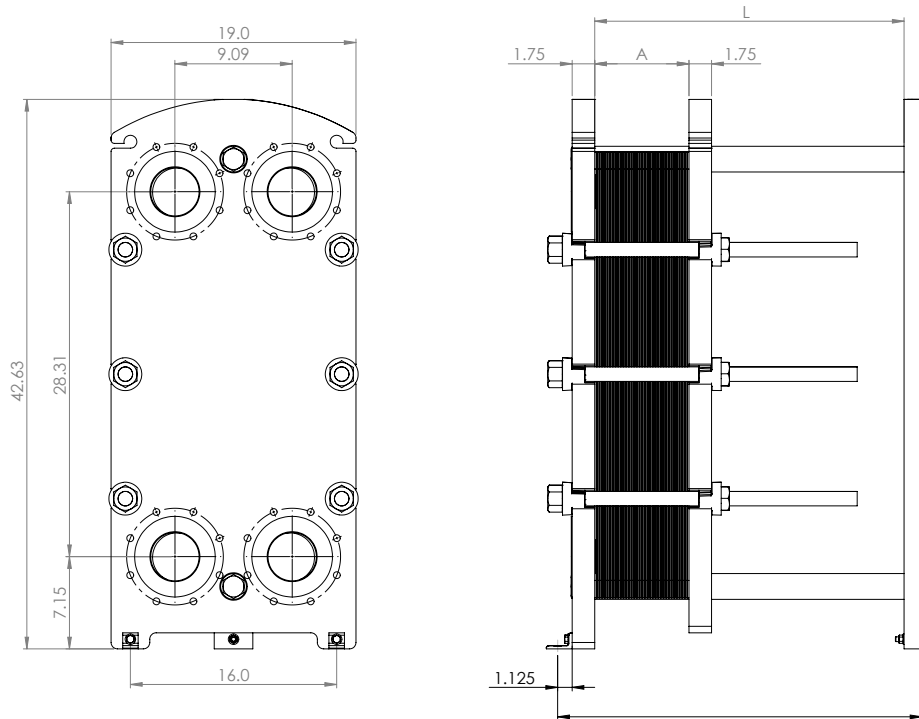

	(L)					
FRAME LENGTH (in)	18	24	30	36	42	48
PLATE CAPACITY	18	35	60	84	105	127

SPECIFICATIONS	WCR A425 Duo
MAWP (PSI)	150 / 300
MAWT (°F)	392
MAXIMUM CONNECTIONS (in)	4"
MAXIMUM FLOW RATE (GPM)	600
MAXIMUM SURFACE AREA (ft²)	298.4
VOLUME / CHANNEL (gal)	0.25

CONNECTION TYPE	
4" STD. STUDED LINED 150 CLASS	
4" FLANGED 150 CLASS	4" TRI CLAMP
4" FLANGED 300 CLASS	4" STUDED LINED 300 CLASS

H1 - FLUID 1 INLET H3 - FLUID 2 INLET
H4 - FLUID 2 OUTLET H2 - FLUID 2 OUTLET

- Plate Material** AISI 316L
- Plate Thickness** 2 x 0.35mm | 2 x 0.4mm
- Gasket Material** NBR | EPDM | HNBR | Viton® | Silicone VMQ® | Alfas®
- Frame Material** Carbon Steel | 304 Stainless Steel
- Frame Finish** Epoxy Coated | Powder Coated | Surface Prep 304
- Tightening Rod** B7 Grade Clear Zinc | B8 Grade Stainless
- Connection Materials** AISI 304L | AISI 316L | Titanium Gr1 | TiPd | H C276 | Ni200
- Connection Type** Studded Lined | Tri-Clamp | Flanged



wcrhx.com

1-800-421-4927